

**TORQUE ARM ASSEMBLY**

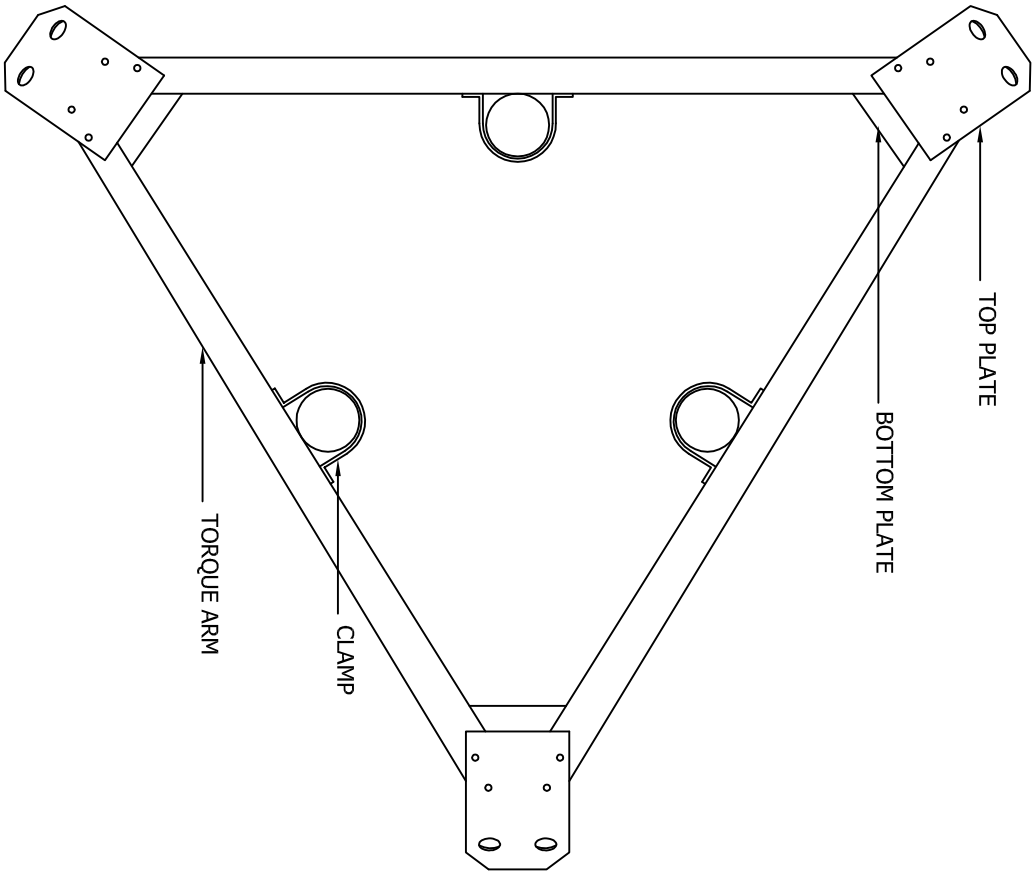

**PLAN**

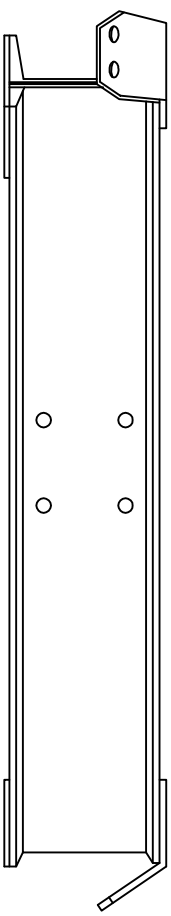

**ELEVATION**

- NOTES:**
1. ALL BOLTS ARE HIGH STRENGTH.
  2. THIS TORQUE ARM IS AVAILABLE FOR TOWER MODELS 55, 65, 82, 83, 84, 85, CC & DD.
  3. TORQUE ARM LUGS ARE PROVIDED FOR TOWERS 55, 65, CC, & DD ONLY. TORQUE ARM BEARS ON BRACE CLIP ON MODEL 80 TOWER.

FILE NO. **Standard-65G**

REVISIONS			
REV.	DESCRIPTION	DW/N	CHK APP
2	REDRAWN INTO AUTOCAD FORMAT	KB2	M.F H.A
DATE: Jan/10/2007			

DWG REFERENCE	

THIS DRAWING IS THE PROPERTY OF ROHN. IT IS NOT TO BE REPRODUCED, COPIED OR TRACED IN WHOLE OR IN PART WITHOUT OUR WRITTEN CONSENT.

**ROHN**  
PRODUCTS

6718 WEST PLANK ROAD  
PEORIA, IL 61604  
TOLL FREE 800-727-ROHN

TORSION RESISTOR ASSEMBLY

DW/N:	CHK'D:	DATE:
RUH	ALG	Jul/25/1969
ENGR:	CW	
DRAWING NO:	C690737	REV: 2